

Bluestem Mountain Banjo Nouveau Plan

Scale / size:	1:1 36" X 20"
Drawn by:	Randy Cordle
Revision date:	12/22/08
File:	Bluestem Banjo Mountain Nouveau.dcd

This drawing provided by Bluestemstrings.com and may not be re-produced, copied, or used for any purpose other than individual use without the express written permission of the author.

NOTE: 36" by 20" drawing size
Print on 24" by 48" or larger paper

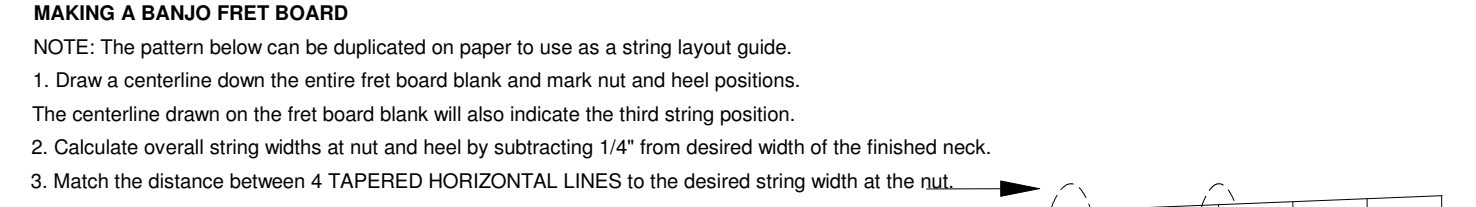
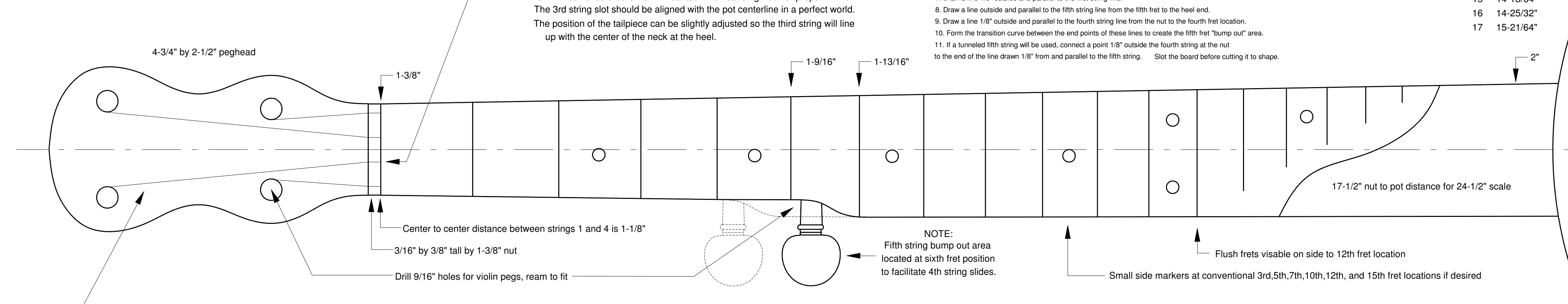

- Flush fret locations measured from nut for 24-1/2" scale instrument:
- 1 1-3/8"
 - 2 2-43/64"
 - 3 3-57/64"
 - 4 5-3/64"
 - 5 6-9/64"
 - 6 7-11/64"
 - 7 8-9/64"
 - 8 9-1/16"
 - 9 9-15/16"
 - 10 10-3/4"
 - 11 11-33/64"
 - 12 12-1/4"
 - 13 12-15/16"
 - 14 13-13/32"
 - 15 14-13/64"
 - 16 14-25/32"
 - 17 15-21/64"

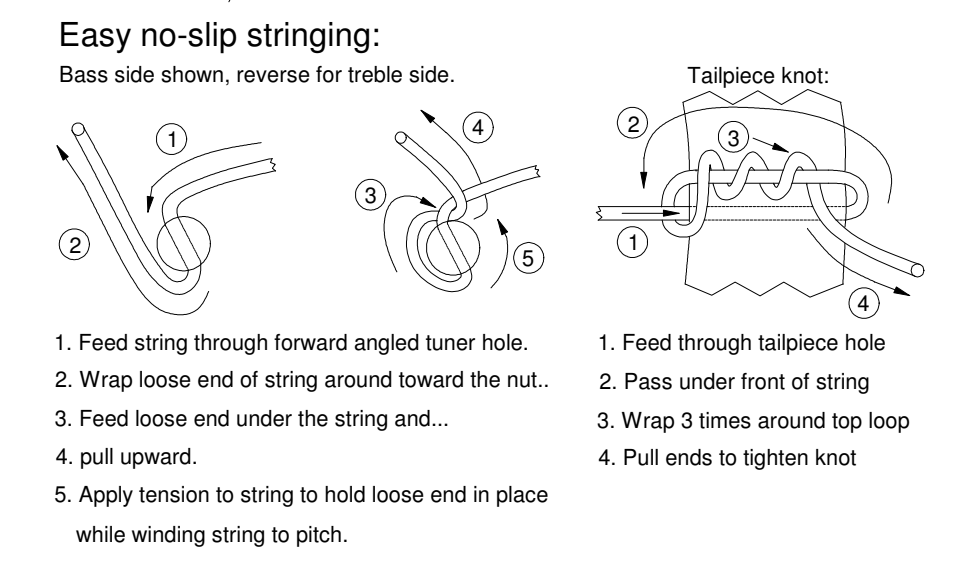
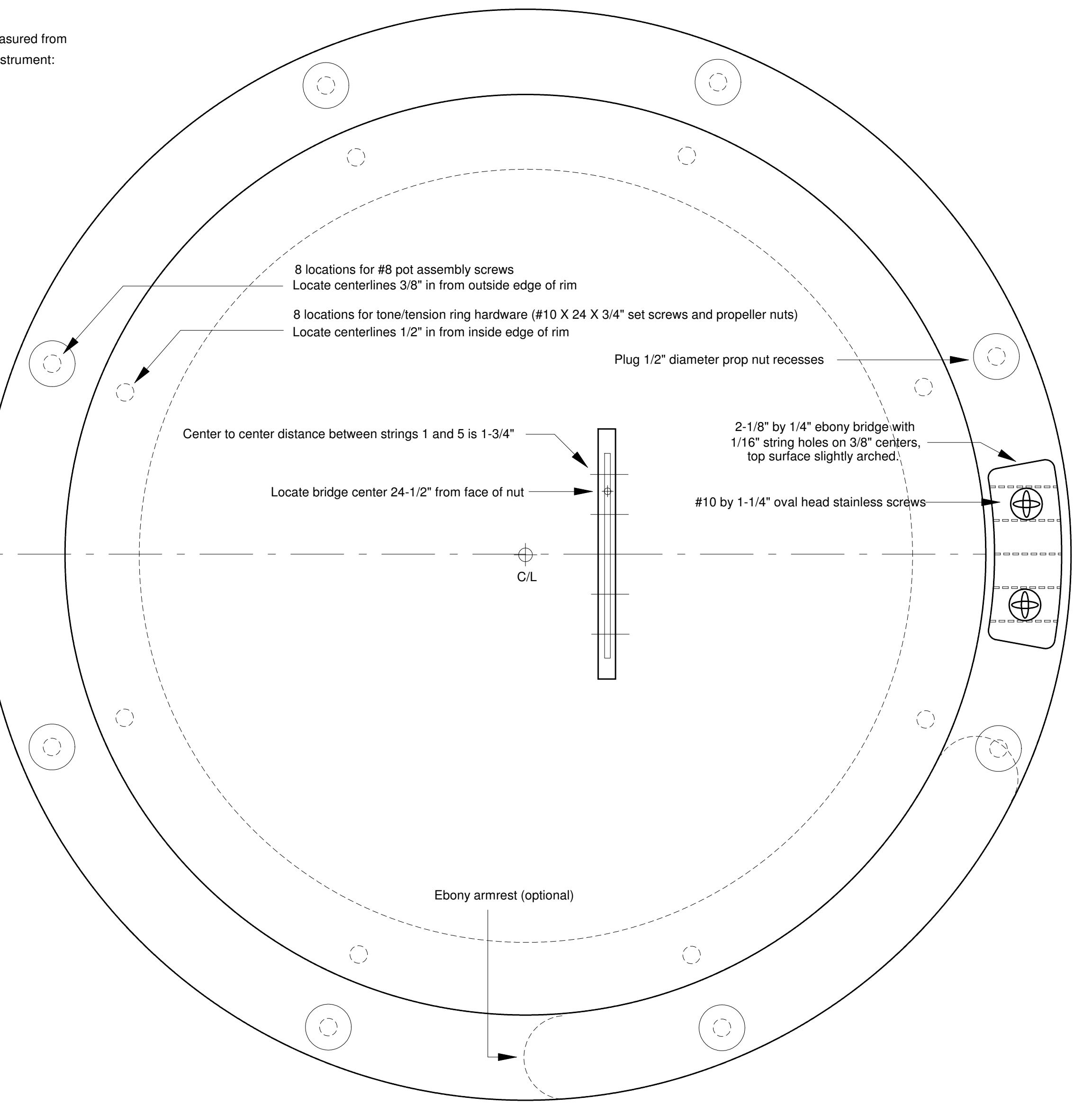

Suggested tuning: eAEAB (fifth string to first string)
 Suggested gauges if using nylon classical guitar strings:
 First string - D'Addario Pro Arte extra hard tension #J4401
 Second string - D'Addario Pro Arte extra hard tension #J4402
 Third string - D'Addario Pro Arte Composite extra hard tension #J4403C
 Fourth string - D'Addario Pro Arte Composite extra hard tension #J4404C
 Fifth string - D'Addario Pro Arte extra hard tension #J4401

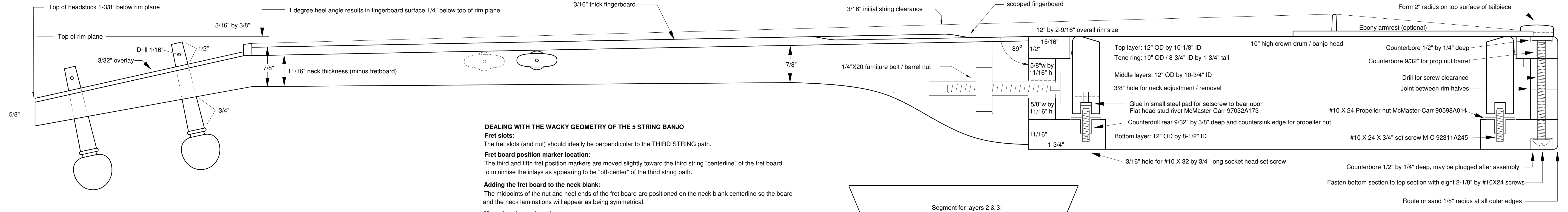
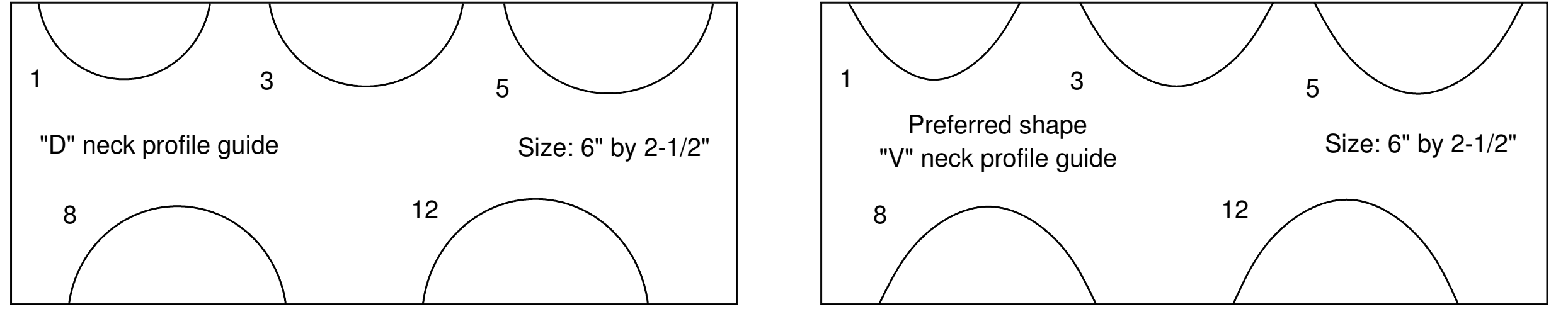

DEALING WITH THE WACKY GEOMETRY OF THE 5 STRING BANJO

Fret slots:
 The fret slots (and nut) should ideally be perpendicular to the THIRD STRING path.

Fret board position marker location:
 The third and fifth fret position markers are moved slightly toward the third string "centerline" of the fret board to minimize the inlays as appearing to be "off-center" of the third string path.

Adding the fret board to the neck blank:
 The midpoints of the nut and heel ends of the fret board are positioned on the neck blank centerline so the board and the neck laminations will appear as being symmetrical.

Mounting the neck to the pot:
 With the neck heel center positioned on the pot centerline, the entire neck is "rotated" slightly clockwise to place the third string nut slot directly over the pot centerline. This is accomplished with the angle of the heel profile cut.

