

Some adjustment to this dimension may be needed to obtain proper "box angle" for 5/8" high bridge use. Test fit box before gluing in place.

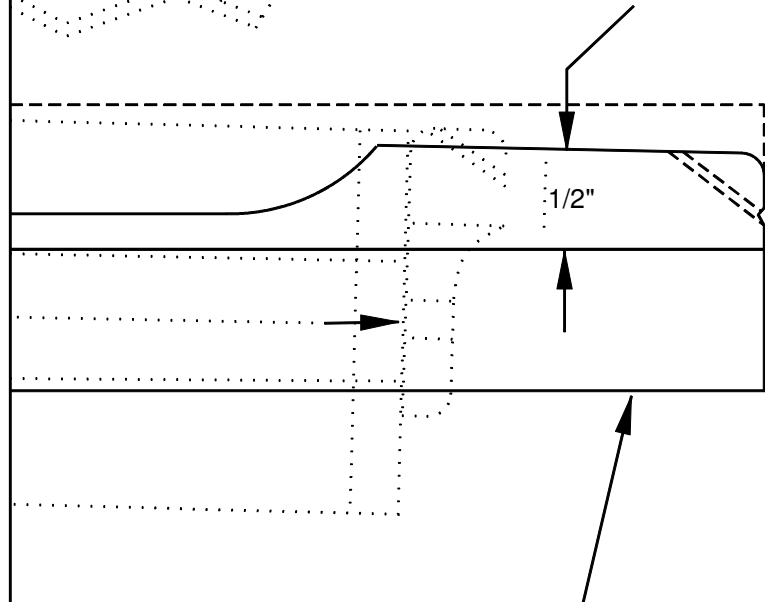

2-7/16" by 15" by 3/4" maple

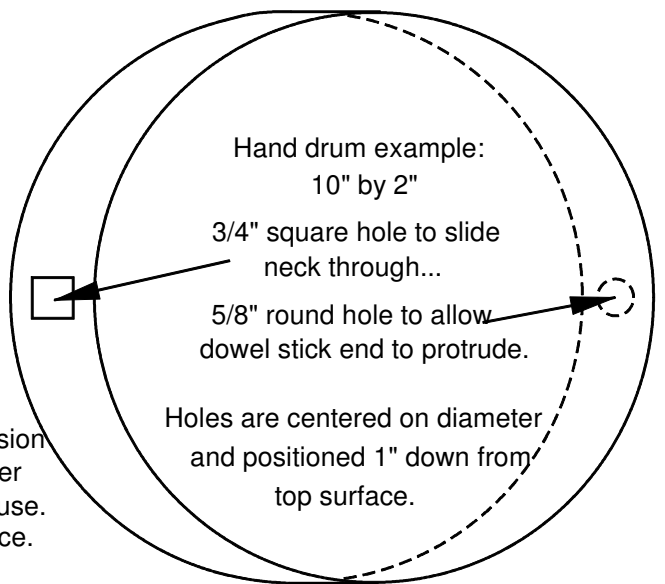
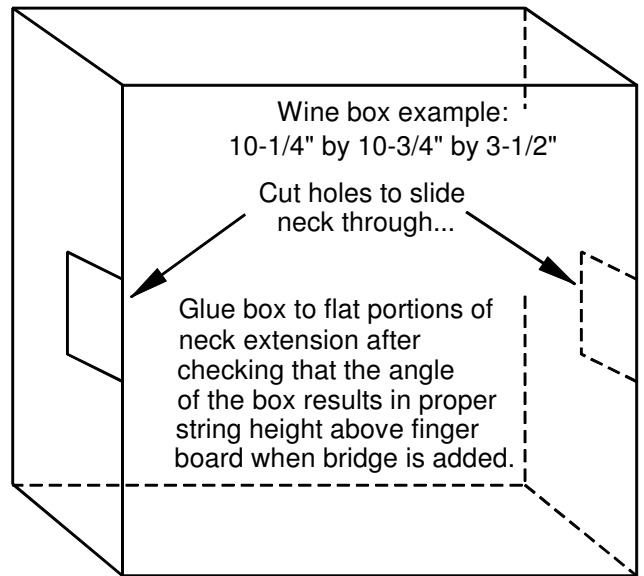

Round over edges / chamfer 1/16" holes

** 1-1/2" by 1-1/4" by 1/2" tailpiece: to use with hand drum version. Round over all edges and chamfer the 1/16" string holes**

